

Monarch[®] 1115[®] Labeler

Operating Instructions

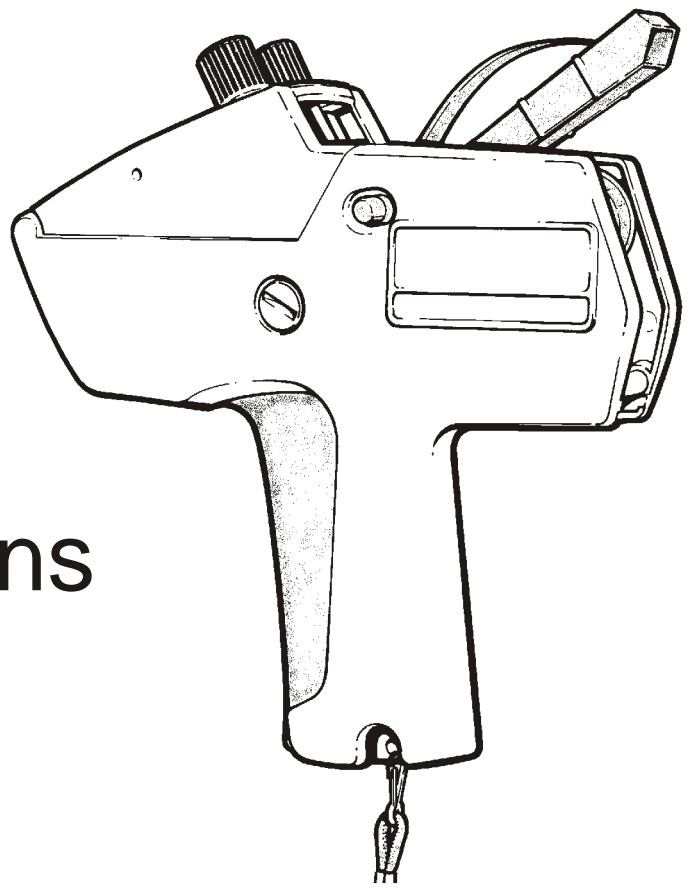

TC1115OI Rev. BF 2/09 ©2006 Avery Dennison Corp. All rights reserved.

LOADING LABELS & SETTING PRINT BANDS

LOADING LABELS

- Slide label roll between hubs. Discard first fourteen labels and backing paper.
- Squeeze operating lever and feed label strip over spring and under brake wheels until about twelve labels come out.
- Feed label strip up under plate until two labels come out. Rewind label roll until loop is removed.

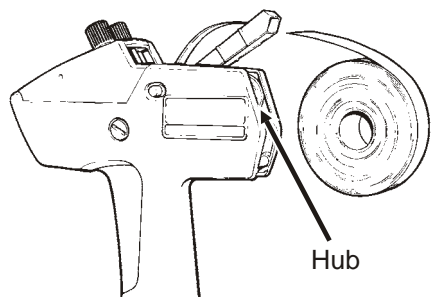

- Pull backing paper to the end of the operating lever, separating labels from backing paper.

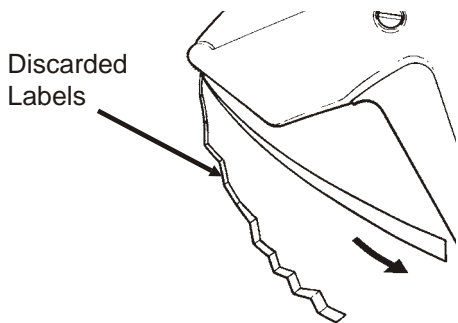

- Hold labeler upside down and while squeezing operating lever, feed backing paper into slot. Squeeze operating lever eight times until backing paper comes through the rear exit.

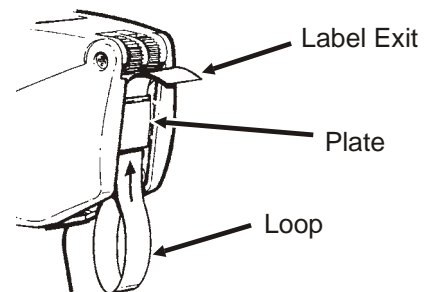
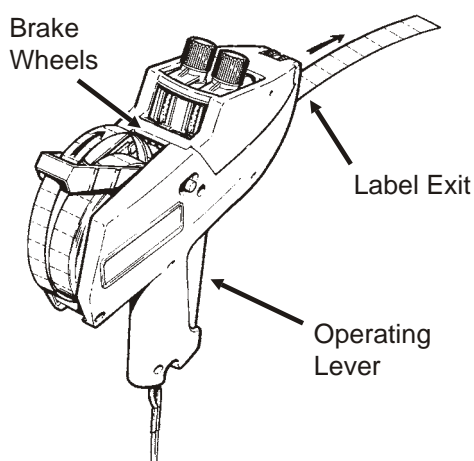

- Tear backing paper evenly between cuts, close to the end of the strip as shown.

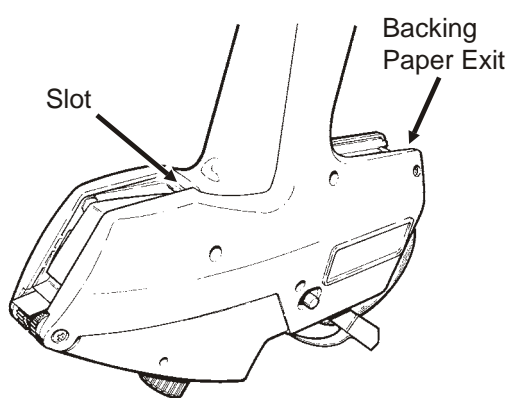
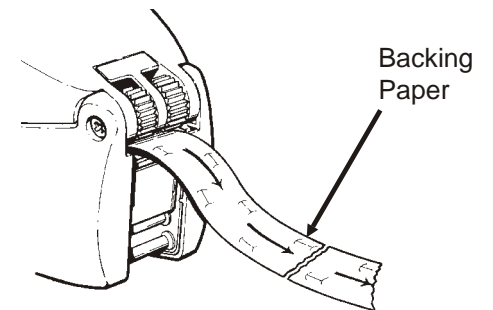

- If backing paper does not become taut and exit at rear: Turn labeler upside down, squeeze operating lever and pull backing paper out of slot. Repeat steps, 4, 5, and 6.

SETTING PRINT BANDS

- Pull the knob until the indicators point to the desired band.
- Turn the knob until the indicators point to desired character or blank.
- Set all bands and push the knob in all the way.

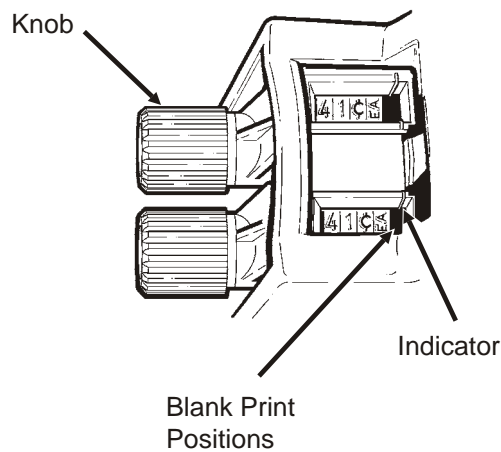

- Print a sample label to insure information is correct.
- If the character prints UPSIDE DOWN, turn the band until you can read the characters correctly. The desired character may be coated with ink.

INKING

- Move two latch buttons toward label roll and swing top cover away from print head.
- Fold a piece of scrap backing paper.
- Insert folded backing paper between ink roll and carrier. Pull to snap old ink roll free.

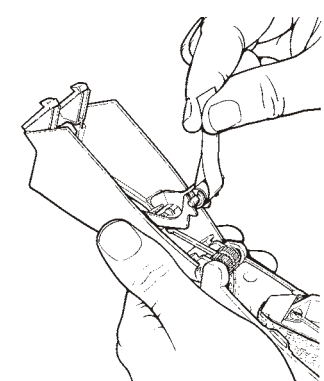
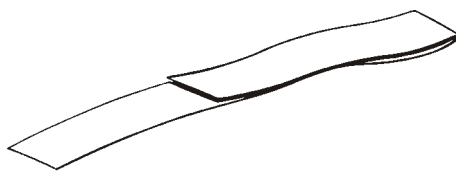
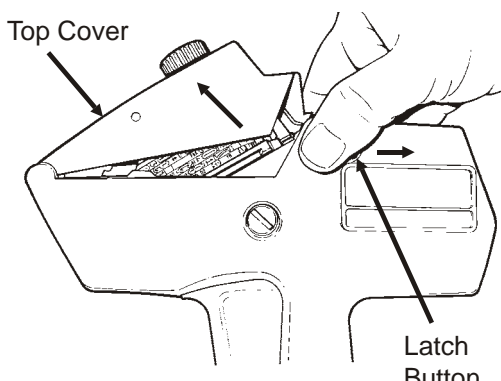

- Cut off end of ink roll package. Using package to protect fingers, slide carrier into package and snap new ink roll into carrier.

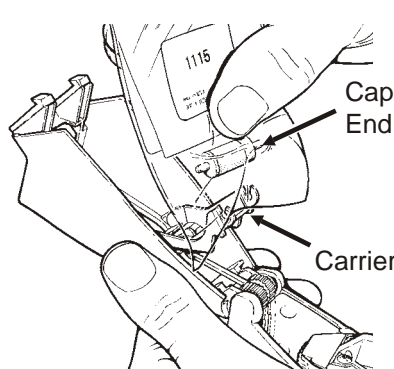

- Snap top cover closed.

OPERATION

INKING

1 Squeeze and release operating lever.

Black Rollers

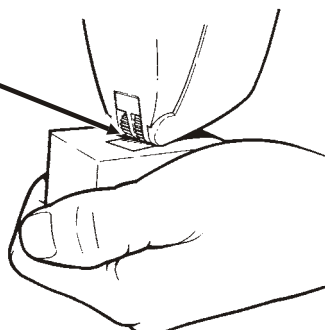

2 Place black rollers on item to be labeled.

DO NOT POUND labeler when applying labels.

3 Pull labeler to apply label. (Gentle wiping motion.)

REMOVING SUPPLIES

1 Tear label strip at label roll as shown and pull label roll from between hubs.

2 Pull label strip from labeler.

3 Squeeze and release operating lever until backing paper is free to be pulled out.

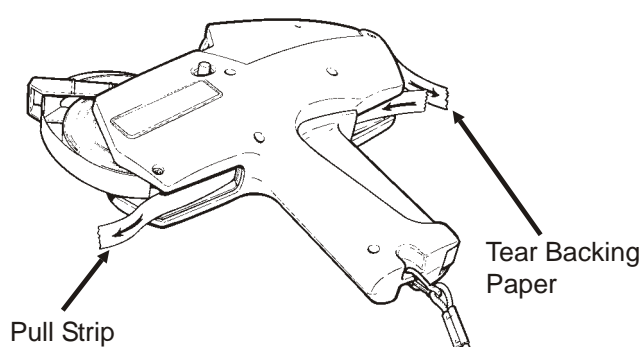
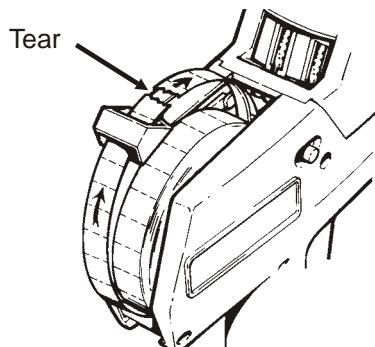

MAINTENANCE

1 With label roll removed, check label track and backing paper track for stray labels.

2 Clear label track by squeezing operating lever and feeding label removal strip under brake wheels and out front of labeler.

3 To clear backing paper track:
a. Insert label removal strip in end of track to loosen stray labels.
b. Insert label removal strip as shown, using corner to remove stray labels.

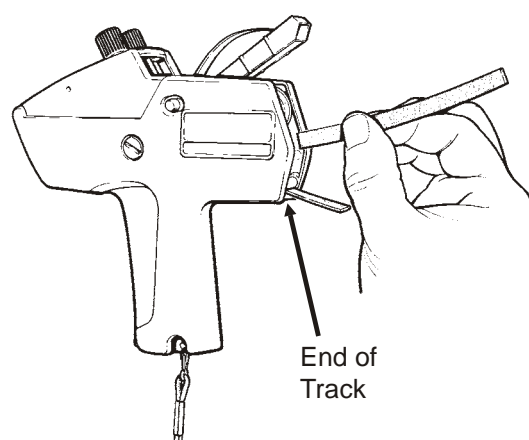
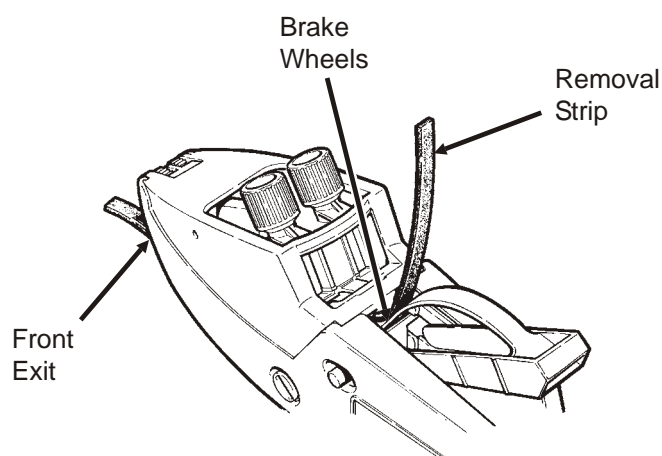

OPERATION, REMOVING SUPPLIES & MAINTENANCE

LUBRICATION

If adhesive buildup occurs, lubricate as shown with labels loaded.

Monarch lubricant is recommended.

Lubricate:
One drop each side of label chute between spring and backing paper.

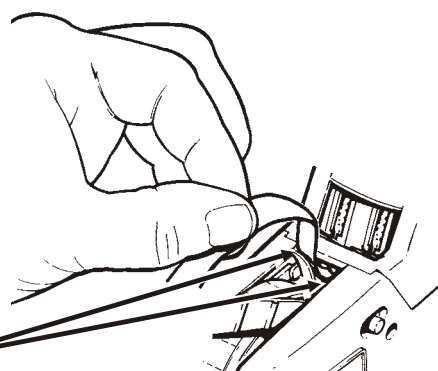

Lubricate:
One drop each spot on backing paper (total of four drops). Spread with finger.

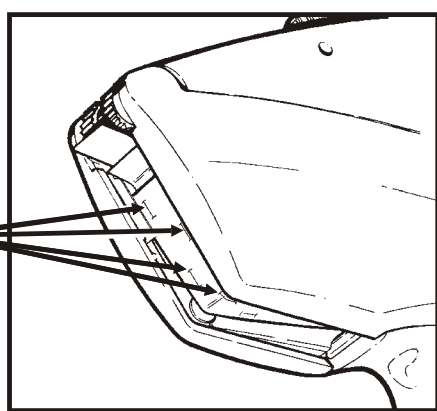

DO NOT OVER LUBRICATE!

PRINT ADJUSTMENT

1 Print location is correct when extreme right-hand and left-hand characters are located as shown.

Approx. 1/16 inch (1.6 mm)



Approx. 1/16 inch (1.6 mm)

2 Place small coin in feedwheel button slot.

Feedwheel Button Slot

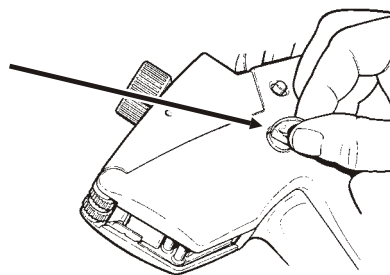

3 Push feedwheel button IN COMPLETELY and turn slightly clockwise if print is too far left or slightly counterclockwise if print is too far right. Adjustment made without completely depressing button are temporary.

4 Repeat steps 2 and 3 until print is correctly located.

TROUBLESHOOTING

Trouble	Remedy
Characters not printing. Bands not inked.	Check ink roll per Inking instructions.
Labels feed slowly or hesitantly.	Follow Lubrication and Maintenance Instructions.
Labels will not feed.	Reload per instructions. Use correct supplies.
	Follow Maintenance instructions.
Print incorrectly located.	Follow Print Adjustment instructions.
Printing smeared or distorted.	Print several labels (15 to 25) to use up excess ink.
Printing too light.	Squeeze operating lever harder during operation.

Warranties

Product warranty statements may vary from country to country. Please contact the authorized Avery Dennison representative in your country for details.

Visit www.monarch.com for sales, service, supplies, information, and telephone numbers of our locations throughout the world.

TOLL FREE:
1-800-543-6650 (In the U.S.A.)
1-800-387-4740 (In Canada)